

**SONY**

AUDIO MIXER

# **MX-P61VU**

# **MX-P61PK**



MX-P61 VU (equipped with the VU meters)



MX-P61 PK (equipped with the peak program meters)

## **MX-P61VU**

Serial No. 10041 and Higher (J)  
Serial No. 20081 and Higher (U)  
Serial No. 30001 and Higher (C)  
Serial No. 50011 and Higher (AEP)

## **MX-P61PK**

Serial No. 18001 and Higher (J)  
Serial No. 28026 and Higher (U)  
Serial No. 38001 and Higher (C)  
Serial No. 58041 and Higher (AEP)

**OPERATION AND MAINTENANCE MANUAL**  
1st Edition (Revised 10)

## SECTION 1 OPERATION

The MX-P61VU/PK\* is a 12-input/4-output multi-purpose audio mixer with many functions for full creative flexibility. The compact and lightweight design demonstrates its ability especially outdoors for relay broadcasting or public address.

\*MX-P61VU: equipped with VU meters  
MX-P61PK: equipped with peak program meters

### 1-1. FEATURES

#### Variety of inputs and outputs

In addition to 12 microphone/line inputs (MIC/LINE INPUT) and 4 line outputs (LINE OUT), 2 auxiliary inputs and 3 outputs are provided for additional mixing effects.

The monitor circuits with two sets of inputs (MONITOR IN) and outputs (MONITOR OUT) permit direct monitoring of each input and output signal.

The connectors for the talk-back circuit (TB OUT) and the pre-fader listening (PFL OUT) allow more accurate mixing.

#### Power supply circuits for condenser microphones

The built-in power supply circuits can supply the required power (12V dc or 48V dc) to connected microphones through the MIC/LINE INPUT connectors.

#### Two-way powering

The MX-P61VU/PK operates either on ac power or on 12V dc.

The operating ac voltage can be selected between 100-120V and 220-240V.

#### Three output level settings

The reference output level at the LINE OUT and AUX OUT connectors can be set to +4dBs, +6dBs or +8dBs, as required.

#### Cascade connection

Two (or more) MX-P61VU/PK sets can be connected in parallel to increase the number of inputs.

#### Output limiters

The output limiter circuits in the line output block suppress any peak over the reference output level to eliminate undesirable distortion.

#### Grouping function

Line output channels 1 and 2 can be mixed on channels 3 and 4 as a group by collectively adjusting the mixing level with the MASTER 1 fader.

#### 1kHz oscillator

The built-in oscillator supplies test and balancing signals for accurate level setting.

#### Supplementary tally circuit

A 4-pin connector and a switch compose a supplementary circuit to control external equipment which requires synchronous operation.

## 1-2. SPECIFICATIONS

0dBs=0.775V

Inputs	No.	Connector	Reference input level	Maximum input level	Input impedance
MIC/LINE INPUT	12	XLR-3-31 type	selectable MIC: -70/-50/-30dBs LINE:+4dBs	selectable MIC: -40/-20/0dBs LINE:+24dBs	10kohms, balanced
SUB IN	2	XLR-3-31 type	+4dBs	+24dBs	10kohms, balanced
MONITOR IN	2	XLR-3-31 type	+4dBs	+24dBs	10kohms, balanced
COMM IN	1	XLR-3-31 type	+4dBs	+24dBs	10kohms, balanced

Pin arrangement (XLR-3-31 type) 1. GND, 2. hot, 3. cold

Outputs	No.	Connector	Reference output level	Maximum output level	Output impedance
LINE OUT	4	XLR-3-32 type	selectable +4/+6/+8dBs (600ohm load)	+24dBs* (600ohm load)	150ohms, balanced
AUX OUT	3	XLR-3-32 type	selectable +4/+6/+8dBs (600ohm load)	+24dBs* (600ohm load)	150ohms, balanced
MONITOR OUT	2	XLR-3-32 type	0dBs (10kohm load)	+20dBs (10kohm load)	20ohms, unbalanced
PFL OUT	1	XLR-3-32 type	0dBs (10kohm load)	+20dBs (10kohm load)	20ohms, unbalanced
TB OUT	1	XLR-3-32 type	0dBs (10kohm load)	+20dBs (10kohm load)	less than 600ohms, unbalanced
PHONES	2	stereo phone	1mW (8ohm load)	30mW (8ohm load)	51ohms

Pin arrangement (XLR-3-32 type)

\*18dBs for unbalanced type

LINE OUT, AUX OUT: 1. GND, 2. hot, 3. cold

PFL OUT, MONITOR OUT, TB OUT: 1. GND, 2. hot, 3. GND

Frequency response  
30Hz-20kHz (+0.5dB)

Harmonic distortion  
Less than 0.1% (reference output level, 1kHz)

Equivalent input noise

Microphone inputs:  
-125dBs(input 150ohms terminated, 20Hz-20kHz)

Line input:  
-75dBs(input 600ohms terminated, 20Hz-20kHz)

Inherent noise  
-75dBs(Master faders at ∞)

Crosstalk

Between input channels:  
70dBs (15kHz)

Between output buses:  
50dBs (15kHz)

Equalizer

High: 10kHz+12dB, shelving  
Mid: 500/1k/2k/4k/8kHz+12dB, peaking  
Low: 100Hz+12dB, shelving

Filter

Low-cut filter: 100Hz, 12dB/oct.  
High-cut filter: 10kHz, 12dB/oct.

Limiter

Threshold level: 0/+2/+4/+6/+8dB from the reference level  
Attack time: 20 usec  
Recovery time: 100msec  
Compression ratio: 3 to 1

Oscillator

Frequency: 1kHz  
Harmonic distortion: Less than 3%

Talk-back microphone  
Electret-condenser microphone

Indicators

VU meters (MX-P61VU)  
Peak program meters (MX-P61PK)

Power requirements

AC: 100-120V or 220-240V selectable, 50/60Hz  
DC: 12V (with the XLR-4-32 type connector)

Power consumption

AC: 52W  
DC: 50W

Operating temperature  
-10° to +50°C (14° to 122°F)

Storage temperature  
-20° to +60°C (-4° to +140°F)

Dimensions  
approx. 430 x 130 x 560mm (w/h/d)  
(17x5<sup>1</sup>/<sub>8</sub>x22<sup>1</sup>/<sub>8</sub> inches)  
incl. projecting parts

Weight  
approx. 18.5kg (40 lb 13 oz)

Supplied accessory

AC power cord (1)  
Operation and Maintenance manual (1)

Optional accessory

Cascade cable ECP-1.5P15  
(Other service parts are also optionally available. Please consult your Sony dealer.)

Design and specifications subject to change without notice.

### 1-3. PARTS IDENTIFICATION

#### 1-3-1. Connector Panel and Bottom

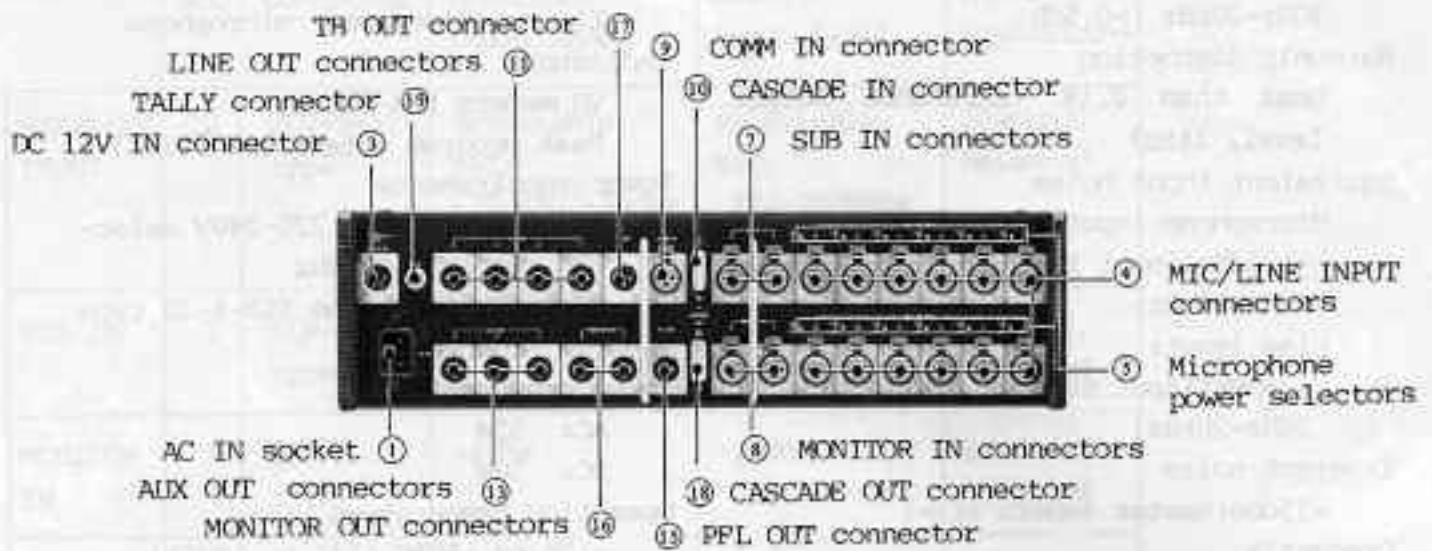

Front cover lock levers  
(To remove the cover, refer to page 1-13.)

⑲ PHONES jack

② Voltage selector

Remove the lid for access to the following.

Microphone main power switches ⑥

LINE output level selector ⑫

AUX output level selector ⑭



## POWER SECTION

### ① AC IN socket

Accepts an ac power source through the supplied ac power cord. The operating voltage can be switched by the voltage selector ②.

### ② Voltage selector (bottom of the unit)

Set this selector to the operating ac voltage, 100-120V or 220-240V, according to the local power supply.

### ③ DC 12V IN connector

Accepts an external 12V dc power source, such as a Sony BP-90 battery pack.

The dc power backs up the ac power.

## INPUT SECTION

### ④ MIC/LINE INPUT connectors 1-12

(XLR-3-31 type, balanced)

Each of these connectors accepts either microphone or line input signals by switching the INPUT level selector ③ on the corresponding input unit.

12V dc (10mA/channel) or 48V dc (7mA/channel) can be supplied through these connectors to externally powered condenser microphones.

### ⑤ Microphone power selectors

Set these selectors to suit to the power requirements of the microphones connected to the respective MIC/LINE INPUT connectors ④.

+48V: For phantom powered condenser microphones.

OFF: For microphones requiring no external power.

Both 12V and 48V dc power are turned off at this position.

+12V: For microphones of the AB feed powering system.

Check that the appropriate microphone power switch ⑥ is set to ON to supply the power.

### ⑥ Microphone main power switches

(bottom of the unit)

Turn on and off the 12V or 48V dc power to all the MIC/LINE INPUT connectors collectively.

### ⑦ SUB IN connectors 1-2

(XLR-3-31 type, reference input level +4dBs, balanced)

Accept auxiliary input signals such as those from an echo machine. The controls to adjust and output these signals are provided on the MASTER 1 unit.

### ⑧ MONITOR IN connectors 1-2

(XLR-3-31 type, reference input level +4dBs, balanced)

Accept external signals to be monitored, as signals which have been broadcast or recorded from the mixer. The controls for this connector are provided on the MASTER 2 unit.

### ⑨ COMM IN (communication input)

connector (XLR-3-31 type, reference input level +4dBs, balanced)

For communication among the operating staff. The signal from this connector will be mixed on the output to the headphones when the COMM IN switch ⑩ on the MASTER 2 unit is depressed.

⑩ CASCADE IN connector

For connecting the CASCADE OUT connector ⑨ of another MX-P61VU/PK to increase the number of inputs. For connection, use the optional ECP-1.5P15 cascade cable.

All inputs of both MX-P61VU/PK units can be mixed and output from the MX-P61VU/PK using the CASCADE IN connector.

OUTPUT SECTION

⑪ LINE OUT connectors 1-4

(XLR-3-32 type, balanced)

Feed out the mixed line output signals.

Connectors 1 and 2 provide a stereo pair of output channels which are controlled by the MASTER 1 fader ⑤, and connectors 3 and 4 provide another pair controlled by the MASTER 2 fader ⑩.

The reference output level can be varied with the LINE output level selector ⑫.

⑫ LINE output level selector

(bottom of the unit)

Selects the reference output level at the LINE OUT connectors ⑪; +4, +6, or +8dBs.

⑬ AUX OUT (auxiliary output)

connectors 1-3 (XLR-3-32 type, balanced)

Each supplies a monaural output signal independently of the LINE OUT connectors.

The reference output level can be varied with the AUX output level selector ⑭.

⑭ AUX output level selector

(bottom of the unit)

Select the reference output level at the AUX OUT connectors ⑬; +4, +6 or +8dBs.

⑮ PFL OUT (pre-fader output) connector  
(XLR-3-32 type, reference output level 0dBs, unbalanced)

For monitoring the pre-fader signals of the input from the MIC/LINE INPUT connectors ④.

Press the PFL switch ⑲ on the input unit corresponding to the desired MIC/LINE INPUT connector and the pre-fader signal is fed to this PFL OUT connector and the PHONES jack

⑳.

⑯ MONITOR OUT connectors 1-2

(XLR-3-32 type, reference output level 0dBs, unbalanced)

For speaker monitoring. Connect a power amplifier to drive the monitor speakers.

The signals to be monitored can be selected with the MONITOR SELECT switch ⑳ on the MASTER 2 unit.

⑰ TB OUT (talk-back output) connector

(XLR-3-32 type, reference output level 0dBs, unbalanced)

Feeds the signal from the talk-back microphone ㉑ on the MASTER 1 unit.

⑱ CASCADE OUT connector

Connect to the CASCADE IN connector ⑩ of another MX-P61VU/PK to increase the number of inputs.

⑲ TALLY connector

For the TALLY switch ㉒ on the indication panel. See the description on the switch.

⑳ PHONES (headphones) jack

(stereo phone jack)

For headphone monitoring. Connect a set of headphones having an impedance of 8 ohms or more.

The signals to be monitored can be selected with the MONITOR SELECT switch ⑳ on the MASTER 2 unit.

## 1-3-2. Control Panel

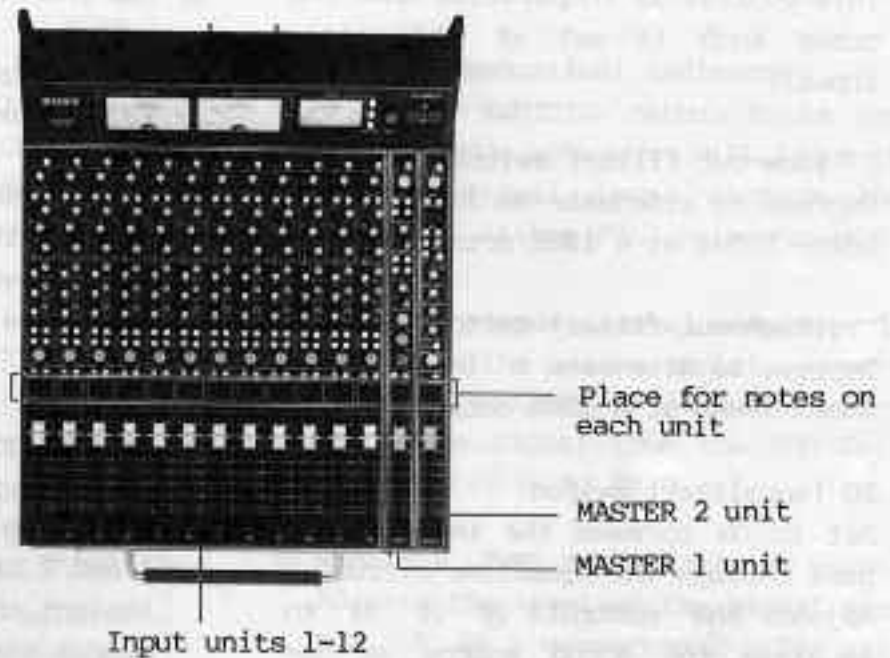

### INPUT UNITS 1-12

The MX-P61VU/PK has 12 input units (channel 1 to 12). Each corresponds to the MIC/LINE INPUT connector ① with the same channel number. The parts on all the input units function the same for the corresponding channels.

#### ① PEAK indicator

Lights up when the incoming signal level is within 5dB of the clipping level at the built-in head amplifier block.

#### ② PHASE selector

To reverse the input phase.

#### ③ INPUT level selector (outer knob)

Selects the input reference level according to the connected signal source; +4dB for line inputs, -30dB, -50dB, or -70dB for microphone inputs.

For microphone inputs, adjust the inner knob ④ after setting this selector.

#### ④ INPUT (microphone input) level fine control (inner knob)

Finely adjusts the microphone input level. The level selected at the outer knob ③ is obtained when this control is turned fully clockwise and can be adjusted to -20dB by turning it counterclockwise.

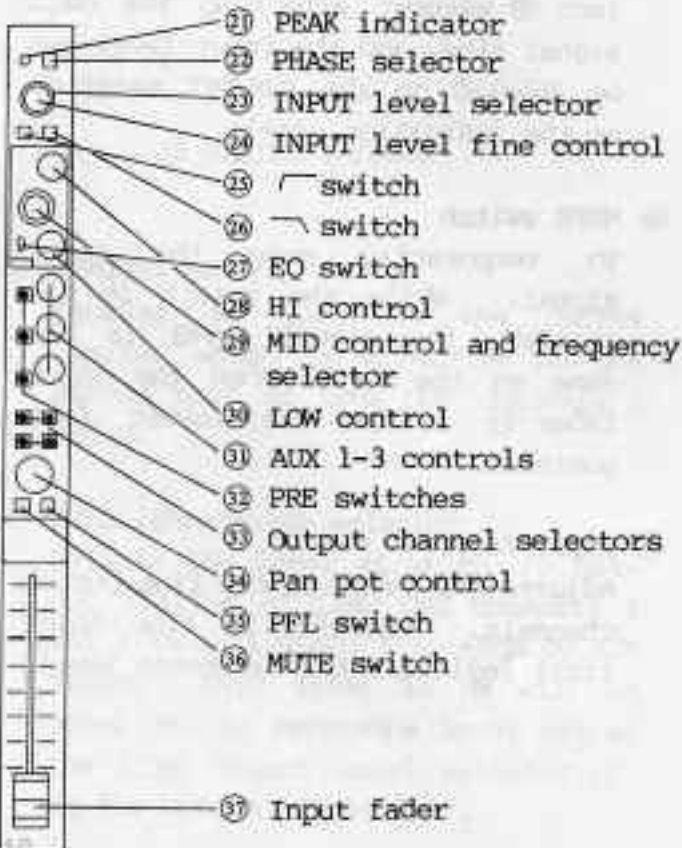



This control is inoperative when the outer knob is set at +4dB (line input).

- ⑲ / (low-cut filter) switch  
Depress to attenuate an input signal below 100Hz at a 12dB/octave rate.
- ⑳ \ (high-cut filter) switch  
Depress to attenuate an input signal above 10kHz at a 12dB/octave rate.
- ㉑ EQ (equalizer) switch  
Set to ON to make the input signal pass through the equalizer circuits. Adjust the controls ㉒ ㉓ ㉔ to equalize the sound source as desired.
- ㉒ HI (high-frequency) control (shelving type)  
Varies the response curve in the high-frequency range around 10kHz within 12dB.
- ㉓ MID (middle-frequency) control and frequency selector (peaking type)  
To vary the response curve in the middle-frequency range. Select the center frequency of the range with the outer knob: 500, 1k, 2k, 4k or 8kHz. Turn the inner control to vary the curve in 12dB.
- ㉔ LOW (low-frequency) control (shelving type)  
Varies the response curve of the low-frequency range around 100Hz within 12dB.
- ㉕ AUX 1-3 (auxiliary output level) controls  
Adjust the level of the auxiliary output channels. The gain margin at the maximum setting is 10dB.

- ㉖ PRE (AUX 1-3 pre-fader output) switch  
Depress to feed the pre-fader signal to the auxiliary output channels.
- ㉗ Output channel selectors 1-4  
Depress the selector(s) corresponding to the line output channel(s) on which the incoming signal is to be mixed.
- ㉘ Pan pot control  
Permits panning of the incoming signal between line output channels 1 and 2 or between channels 3 and 4. (Select the output channels with the output channel selectors ㉙.)  
At the center click position, the sound image is in the center.
- ㉙ PFL (pre-fader listening) switch  
While this switch is depressed, the pre-fader input signal is fed to the PFL OUT connector ㉚ and the PHONES jack ㉛ without affecting the main signal flow, and the input level can be checked on the AUX/PFL meter ㉜ on the indication panel.
- ㉚ MUTE switch  
To temporarily mute the input signal. While the switch is depressed, the signal level is the same as the level when the input fader ㉝ is at its lowest ( $\infty$ ) position.
- ㉝ Input fader  
Adjusts the level to the line output channels. Position 10 (the thick line) indicates the reference level.

## MASTER 1 UNIT

The line output channels 1 and 2 (LINE OUT 1-2), auxiliary inputs (SUB IN 1-2) and auxiliary outputs (AUX OUT 1-3) are controlled by the MASTER 1 unit.

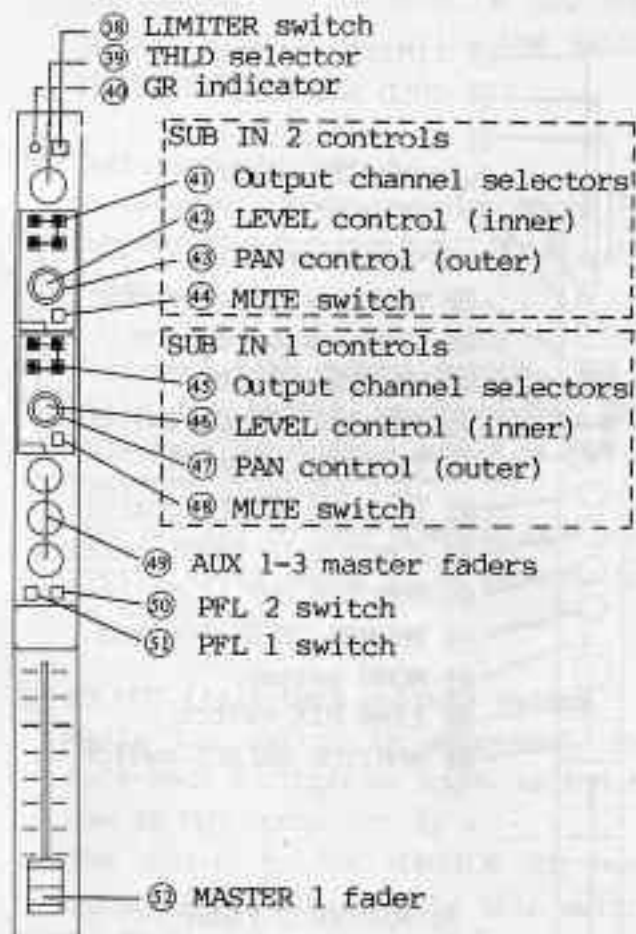

### 38 LIMITER switch

Depress to turn on the output limiter which is effective on the stereo pair of LINE OUT channels 1 and 2.

### 39 THLD (threshold) selector

Selects the level at which the output limiter of LINE OUT channels 1 and 2 is activated; 0 to +8dB by 2dB steps. This level in dB will be based on the reference level set at the LINE output level selector 17 on the bottom of the unit.

### 40 GR (gain reduction) indicator

When the LIMITER switch 38 is set to ON, this indicator will light up if the signal level exceeds the level set at the THLD selector 39.

### 41 SUB IN 2 output channel selectors 1-4

Depress the selector(s) corresponding to LINE OUT channel(s) on which the signal from the SUB IN 2 connector 7 is to be mixed.

### 42 SUB IN 2 LEVEL control (inner knob)

Adjusts the level of the signal from the SUB IN 2 connector 7. The gain margin at the maximum setting is 10dB.

### 43 SUB IN 2 PAN control (outer knob)

Permits panning of the signal from the SUB IN 2 connector 7 between LINE OUT channels 1 and 2 or channels 3 and 4. (Select the output channels with the SUB IN 2 output channel selectors 41.)

At the center click position, the sound image is in the center.

### 44 SUB IN 2 MUTE switch

Depress to mute the signal from the SUB IN 2 connector 7.

### 45 SUB IN 1 output channel selectors

### 46 SUB IN 1 LEVEL control

### 47 SUB IN 1 PAN control

### 48 SUB IN 1 MUTE switch

Function the same on the SUB IN 1 connector as those of the SUB IN 2 connector.

### 49 AUX 1-3 master faders

Adjust the output level of the AUX OUT 1-3 connectors respectively. The gain margin at the maximum setting is 10dB.

⑥ PFL 2 (line output channel 2 pre-fader listening) switch

While the switch is depressed, the pre-fader signal of the LINE OUT channel 2 will be fed to the PFL OUT connector ⑬ and the PHONES jack ⑲, and the AUX/PFL meter ⑮ will show this pre-fader signal level.

⑦ PFL 1 (line output channel 1 pre-fader listening) switch

While the switch is depressed, the pre-fader signal of the LINE OUT channel 1 will be fed to the PFL OUT connector ⑬ and the PHONES jack ⑲, and the AUX/PFL meter ⑮ will show this pre-fader signal level.

⑧ MASTER 1 fader

Adjusts the output level of LINE OUT channels 1 and 2 collectively. Position 10 (the thick line) indicates the reference level.

MASTER 2 UNIT

The LINE OUT (line output) channels 3 and 4, the monitor and communication circuits are controlled by the MASTER 2 unit.

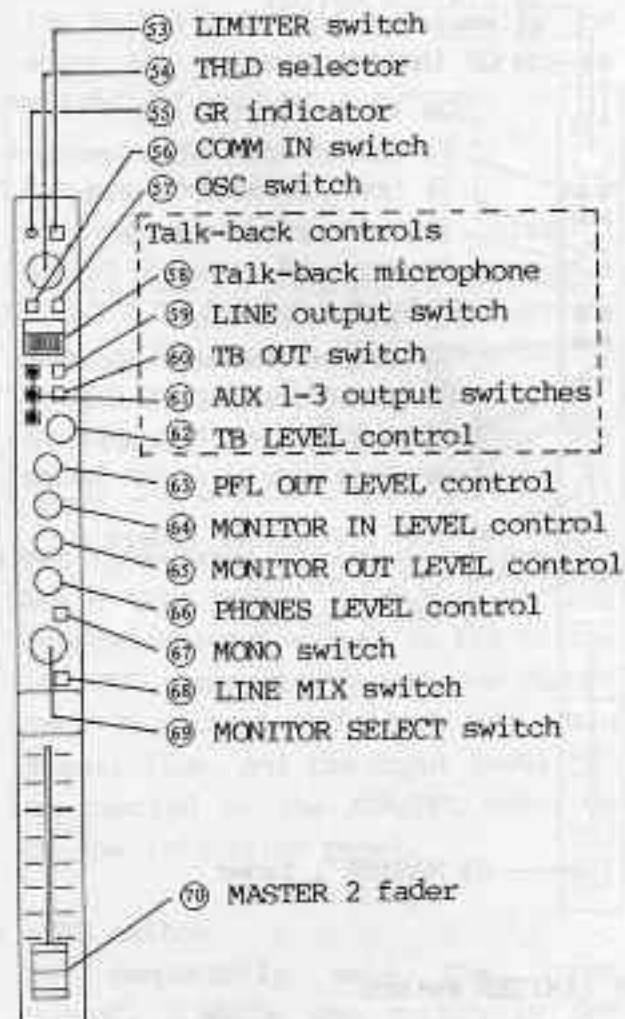

⑥3 LIMITER switch

⑥4 THLD (threshold) selector

⑥5 GR (gain reduction) indicator

Function the same on the stereo pair of LINE OUT channels 3 and 4 as the ⑥3 ⑥4 ⑥5 function on channels 1 and 2.

⑥6 COMM IN (communication input) switch

Depress to mix the signal from the COMM IN connector ⑨ on the output to the PHONES jack ⑲.

- ⑤7 **OSC (oscillator) switch**  
Depress to feed a 1kHz sine-wave to the input channel 12. The controls on the input unit 12 adjust the oscillator signal level and output it to the desired output channel(s). The output to the MONITOR OUT connector ⑭ is muted while the switch is depressed.
- ⑤8 **Talk-back microphone**  
An electret-condenser microphone for supplying information from the mixer.
- ⑤9 **Talk-back LINE output switch**  
While the switch is depressed, the talk-back microphone sound is fed to LINE OUT channels 1-4. The output to the MONITOR OUT connector ⑭ is muted while this switch is depressed.
- ⑥0 **TB OUT (talk-back output) switch**  
While the switch is depressed, the talk-back microphone sound is fed to the TB OUT connector ⑰. The output to the MONITOR OUT connector ⑭ is muted while this switch is depressed.
- ⑥1 **Talk-back AUX 1-3 output switches**  
While the switch(es) is(are) depressed, the talk-back microphone sound is fed to the respective AUX OUT connector(s) ⑱. The output to the MONITOR OUT connector ⑭ is muted while these switches are depressed.
- ⑥2 **TB LEVEL control**  
Adjusts the talk-back microphone sound level. The built-in limiter in the microphone head-amplifier prevents over-loading.
- ⑥3 **PFL OUT LEVEL (pre-fader listening level) control**  
Adjusts the level of the pre-fader listening at the PFL OUT connector ⑲ and the PHONES jack ⑳. The gain margin at the maximum setting is 10dB.
- ⑥4 **MONITOR IN LEVEL control**  
Adjusts the input level of the MONITOR IN connectors ⑳. The gain margin at the maximum setting is 10dB.
- ⑥5 **MONITOR OUT LEVEL control**  
Adjusts the output level of the MONITOR OUT connectors ⑳. The gain margin at the maximum setting is 10dB.
- ⑥6 **PHONES LEVEL control**  
Adjusts the output level of the PHONES jack ⑳.
- ⑥7 **MONO (monaural monitoring) switch**  
Depress to monitor the signal in monaural through the MONITOR OUT connectors ⑲ and the PHONES jack ⑳.
- ⑥8 **LINE MIX (line mixing) switch**  
For using LINE OUT channels 1 and 2 to group the input signals to be mixed on channels 3 and 4. When the switch is depressed, LINE OUT channels 1 and 2 are mixed onto channels 3 and 4 at the level defined by the MASTER 1 fader. Channel 1 is mixed on channel 3 and channel 2 on channel 4.

⑧⑨ MONITOR SELECT switch

Selects the signal to be monitored.  
MONITOR IN: Signals from the MONITOR IN connectors.

LINE 1-2: LINE OUT channels 1 and 2

LINE 3-4: LINE OUT channels 3 and 4

AUX: Auxiliary outputs. Select one of the AUX OUT channels with the AUX 1-3 selectors ⑦⑥ on the indication panel.

⑦⑩ MASTER 2 fader

Adjusts the output level of LINE OUT channels 3 and 4 collectively. Position 10 (the thick line) indicates the reference level.

1-3-3. Indication Panel

MX-P61VU (with VU meters)

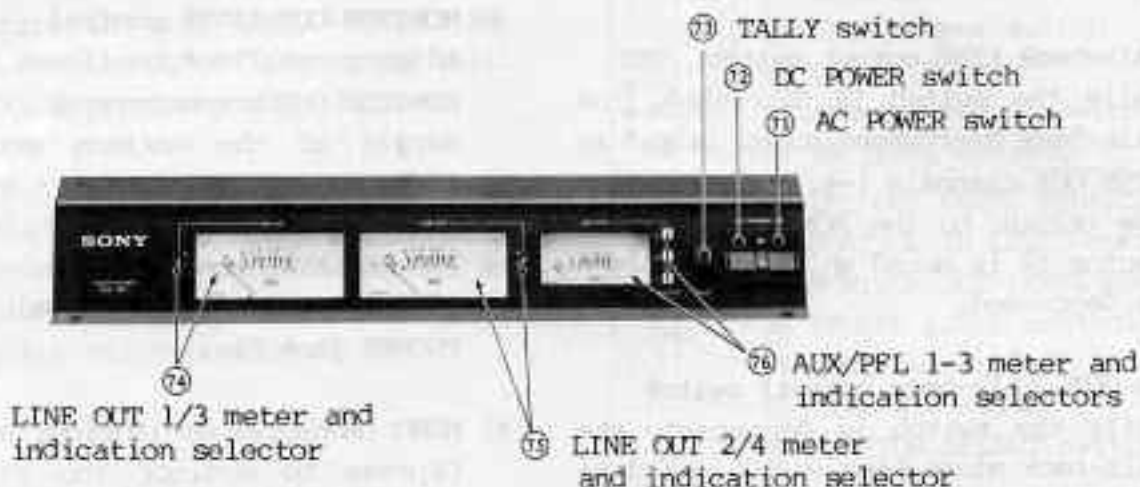

MX-P61PK (with peak program meters)

LINE OUT 1/3 meter and indication selector ⑦④

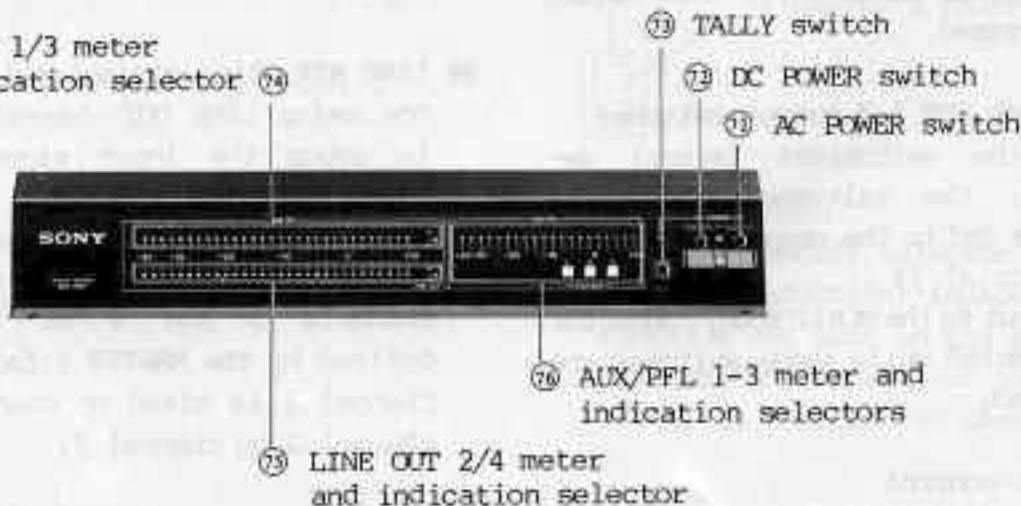

⑦① AC POWER switch  
Turns on and off the ac power.

⑦② DC POWER switch  
Turns on and off the dc power. When both ac power and dc power are turned on, the ac power has priority over the dc power. When the ac power is cut off, the unit is automatically switched to the dc power operation.

⑦③ TALLY switch  
Turns on and off audio equipment, tally lamps, etc. connected to the TALLY connector ⑬ via an appropriate interface unit. The built-in LED in this switch lights up by short-circuiting pin 3 and pin 4 of the TALLY connector.

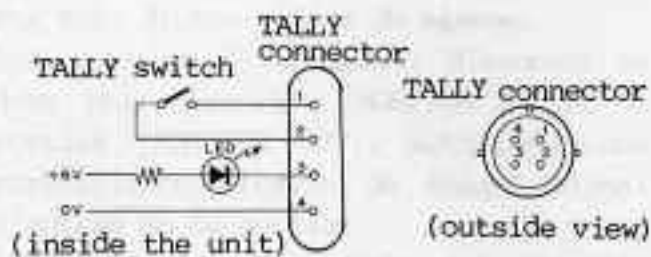

⑦④ LINE OUT 1/3 meter and indication selector  
The meter shows the LINE OUT channel 1 or 3 output level according to the indication selector setting.

⑦⑤ LINE OUT 2/4 meter and indication selector  
The meter shows the LINE OUT channel 2 or 4 output level according to the indication selector setting.

⑦⑥ AUX/PFL 1-3 meter and indication selectors  
The meter shows the AUX OUT channel 1, 2 or 3 level according to the indication selector depressed. These selectors also select the AUX OUT channels to be monitored. While the PFL switch(es) ⑭ on the input unit(s) or the PFL 1 or 2 switch ⑮ or ⑯ on the MASTER 1 unit is(are) depressed, the meter shows the selected pre-fader signal level.

HOW TO REMOVE THE COVER  
Release both the lock levers by sliding them outwards. Raise the cover by approx. 30°, then pull it out toward you. Never try to force the cover to open more than 30°.

